

A3N1024/ 1025/ 1026/ 1027

Bias tee

Features

Wideband: 8kHz to 20GHz

Low insertion loss

Applications

R&D of optical communication

Evaluation of high speed devices

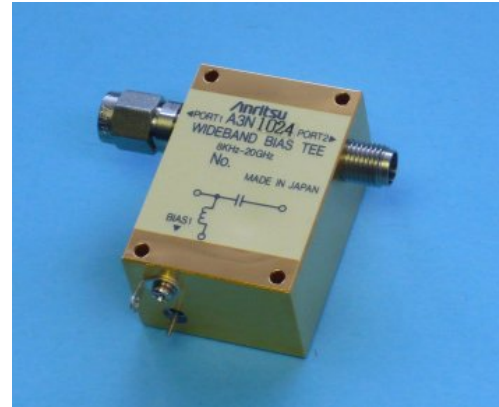

Absolute Maximum Ratings

Items	Ratings
Bias voltage	±30V dc
Bias current	±0.2A
Operating temperature	0°C - 60°C

Specifications

Ta=25°C, Zin=50ohms, Zout=50ohms

Items	Conditions	Units	Specifications		
			min.	typ.	max.
Bandwidth	-3dB	Hz	8k		20G
Insertion loss	8kHz	dB		2	3
	20kHz			0.5	
	1GHz			0.5	
	10GHz			1	
	20GHz			2	3
Return loss	Within bandwidth	dB	10	20	
Tr / Tf	*1	ps		18	
Connectors				K	

*1: $Tr, Tf = (Tm^2 - Ts^2 - Ti^2)^{1/2}$

Tm: Value measured with oscilloscope

Ts: Tr and Tf of oscilloscope

Ti: Tr and Tf of signal generator

Dimensions

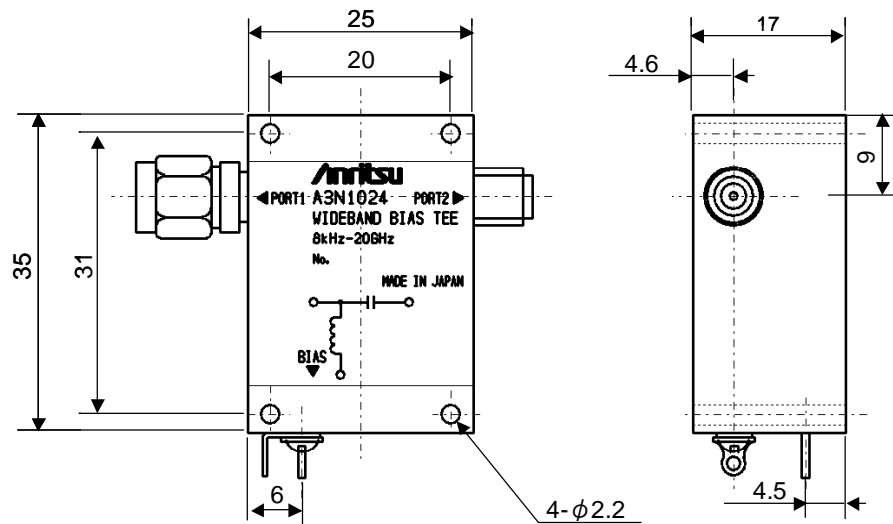

Model	Port1	Port2	Bias
A3N1024	K-M	K-F	Soldering terminal
A3N1025	K-F	K-M	
A3N1026	K-F	K-F	
A3N1027	K-M	K-M	

Electrical Characteristics

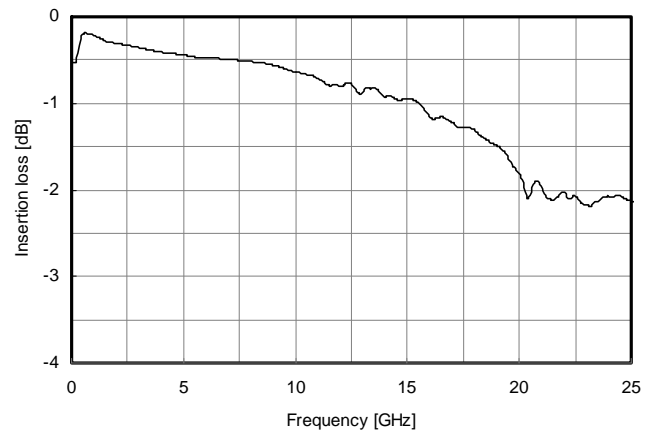
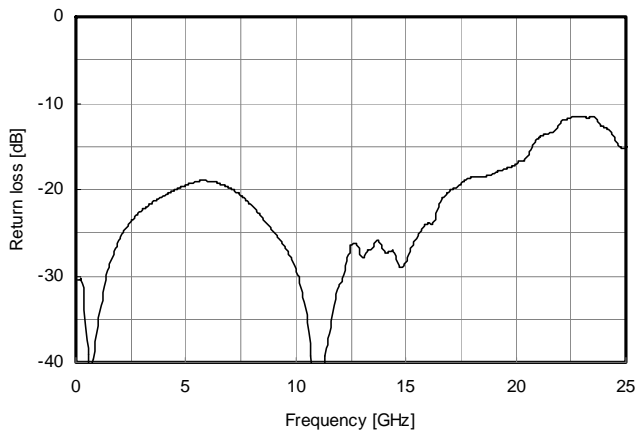

Please consult Anritsu Corporation If the products are used in the high reliability system.
Specifications are subject to change without notice.