



94 JACKSON ROAD, SUITE 110, DEVENS, MA 01434

Electromechanical Line Stretcher

Model RMLS.1800Sfm

SMA female/male

Frequency Range (GHz) FL-Fu	Insertion Loss (dB max)	Impedance	VSWR (max)	Phase Variation (deg/GHz)
DC-18000	$0.2 + 0.04/f$	50 Ω	$\leq 1.35:1$	15

Notes:

- a. Connector: SMA female/male
- b. Operation temperature: -65C to +125C deg
- c. Case material: SS/P

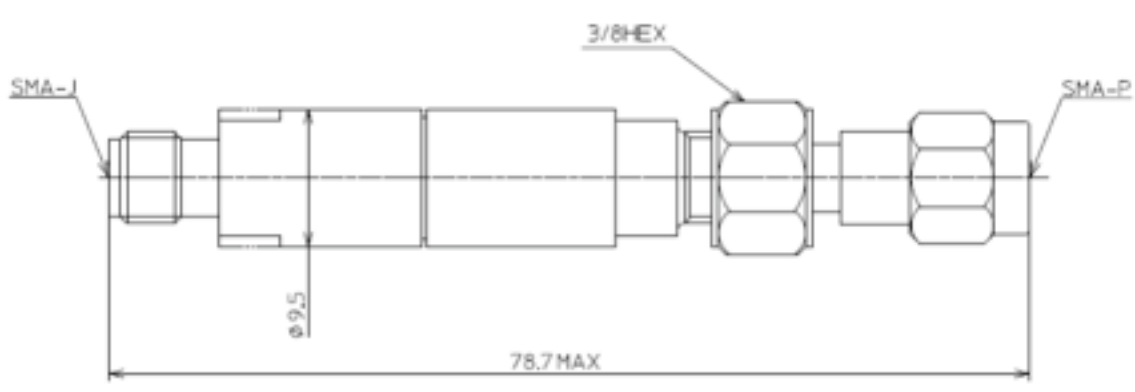

All specifications are subject to change without notice.

Dimensions: mm

Telephone: 978-772-3767

Fax: 978-772-3768

www.responsemicrowave.com

Rev 04/02/12